

# Oilcheck

Hand-held Oil Condition Monitor



Portable and battery powered for 'go-anywhere' monitoring

Hand-held condition monitor provides a visual comparison between new and used oils

Parker's Oilcheck is completely portable and battery powered with a numerical display that indicates positive or negative increase in dielectrics. Oilcheck gives an early warning of impending engine failure and the simplistic hand-held design makes it easy to use.



Oilcheck shown with optional rubberized sleeve.

## Contact Information:

Parker Hannifin  
**Hydraulic Filter Division Europe**

**European Product Information Centre**  
**Freephone: 00800 27 27 5374**  
**(from AT, BE, CH, CZ, DE, EE, ES, FI, FR, IE, IT, PT, SE, SK, UK)**  
**filtrationinfo@parker.com**

[www.parker.com/hfde](http://www.parker.com/hfde)

## Product Features:

- Oilcheck hand-held condition monitor provides a visual comparison between new and used oils.
- The Oilcheck, once calibrated with clean oil, will store the calibration units memory when the unit is switched off, until such time that a re-calibration is required by the user.
- Completely portable and battery powered.
- Numerical display shows positive or negative increase in dielectrics.
- Gives early warning of impending engine failure.
- Optional protective rubberized sleeve.

# Oilcheck

## Hand-held Oil Condition Monitor

### Features & Benefits

- A comparator between new and used oils.
- Oilcheck gives early warning of impending engine failure.
- Cost effective solution to save money and help increase engine life.
- Completely portable, battery powered.
- Ideal for fleet owners, garages and DIY mechanics.
- Numerical display to show positive or negative increase in dielectrics.

### Typical Applications

- Fleet owners
- Construction equipment maintenance
- Vehicle service garages
- Plant hire maintenance

The Oilcheck from Parker Filtration's Condition Monitoring Centre detects and measures the dielectric constant of oil, by comparing the measurements obtained from used and unused oils of the same brand.

Used as a regular service monitoring instrument, the Oilcheck will give the engineer warning of an impending engine failure and promote increased engine life. Oilcheck is the low-cost solution that will take the guesswork out of oil changes, saving money and time.

### Using Oilcheck

Following the simple sampling procedure, Parker's Oilcheck will ensure effective and highly repeatable results. Once a clean oil sample has been placed in the 'Sensor Well' and the 'TEST' button has been pressed, the instrument will 'zero' on the sample.

Once cleaned out with a degreaser and replaced by a contaminated sample, a new reading is obtained on the LCD, which can be easily compared against the green/amber/red efficiency scale.



## Specification

**Case construction:**  
ABS.

**Circuitry:**  
Microprocessor control.

**Battery:**  
1 x 9V alkaline (supplied).

**Display:**  
LCD.

**Suitable oil types:**  
Mineral and synthetic based oils.

**Repeatability:**  
Better than 5%.

**Readout:**  
Green/amber/red grading, Numerical value (0-100%).

**Battery lifetime:**  
>150 hours or 3,000 tests.

**Dimensions:**  
250mm x 95mm x 34mm (9.8" x 3.7" x 1.3").

**Weight:**  
0.4kg.

**Memory capacity:**  
Remembers the last calibration.

## Using Oilcheck



Green/amber/red  
numerical value



Function  
buttons

The Oilcheck can remove the need for costly and time consuming laboratory analysis of mineral and synthetic oils used in engines, gearboxes and bearing lubrication systems. It detects mechanical wear and any loss of lubricating properties in the oil with a repeat accuracy of less than 5%.

The Oilcheck is able to show changes in the oil condition brought about by the ingress of water content, fuel contamination, metallic content and oxidation.

## Installation Details

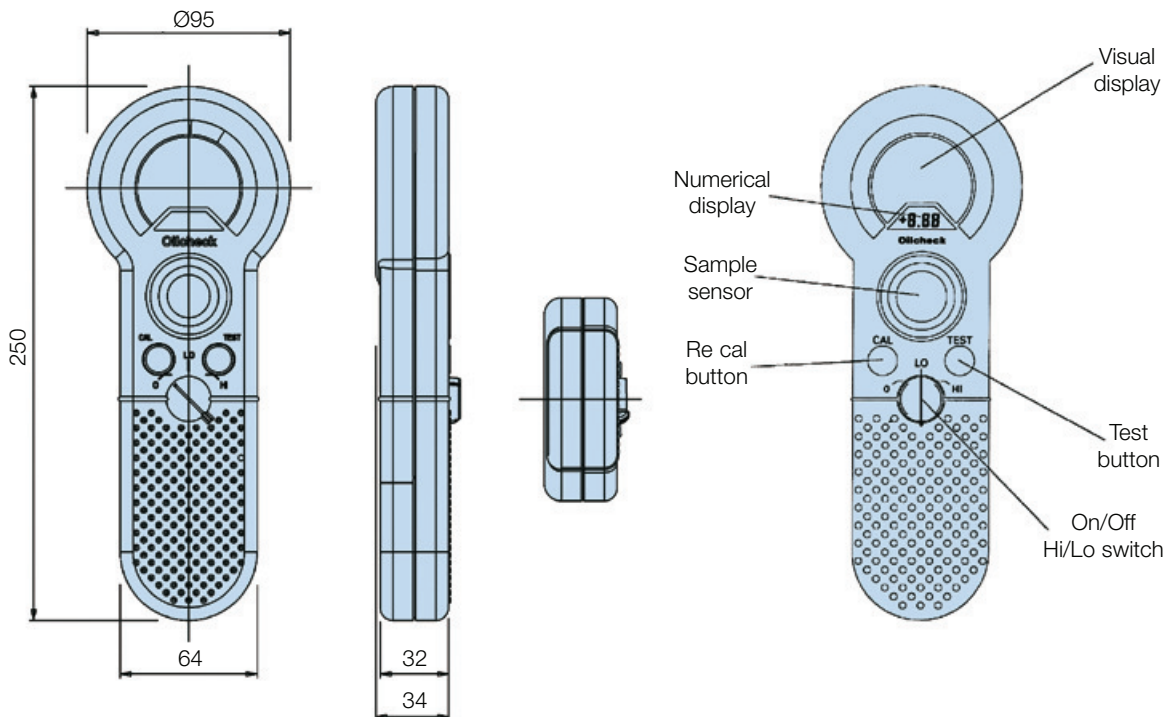

## Ordering Information

### Standard products table

Product number	Description
<b>OLK605</b>	Oilcheck kit with numerical readout
<b>OLK611</b>	Oilcheck cleaner
ACC6NV001	Rubberized protective sleeve

Note 1: Part numbers featured with bold highlighted codes will ensure a 'standard' product selection.

Note 2: Alternate displayed part number selection will require you to contact Parker Filtration for availability.

